

*November 2021*

**Making Leather**  
**AN OVERVIEW OF MANUFACTURE**  
Part 4 of 10  
**The removal of water**  
**and reconfiguration to a flat form**

Author: © Richard P. Daniels

Recommended by:



INTERNATIONAL UNION OF LEATHER  
TECHNOLOGISTS AND CHEMISTS SOCIETIES



UNITED NATIONS  
INDUSTRIAL DEVELOPMENT ORGANIZATION

## Content of Series:

- Part 1: Introduction and raw materials.**
- Part 2: The removal of unwanted materials and extension of the structure.**
- Part 3: The introduction of new materials and extension of the structure.**
- Part 4: The removal of water and reconfiguration to a flat form.**
- Part 5: Application of the finish.**
- Part 6: Different types of bovine leathers.**
- Part 7: Small skins: hair sheep and goat: grain leathers.**
- Part 8: Small skins: wool bearing sheep: double face, shearling and rugs.**
- Part 9: Discussion.**
- Part 10: Annex.**

*All rights reserved. This publication is for free dissemination and any associated charges. It should only be transmitted or used in its entire form. The rights of Richard Daniels to be identified as author of this work is asserted in accordance with the Copyright, Design and Patents Act 1988.*

## Stage 3 procedures

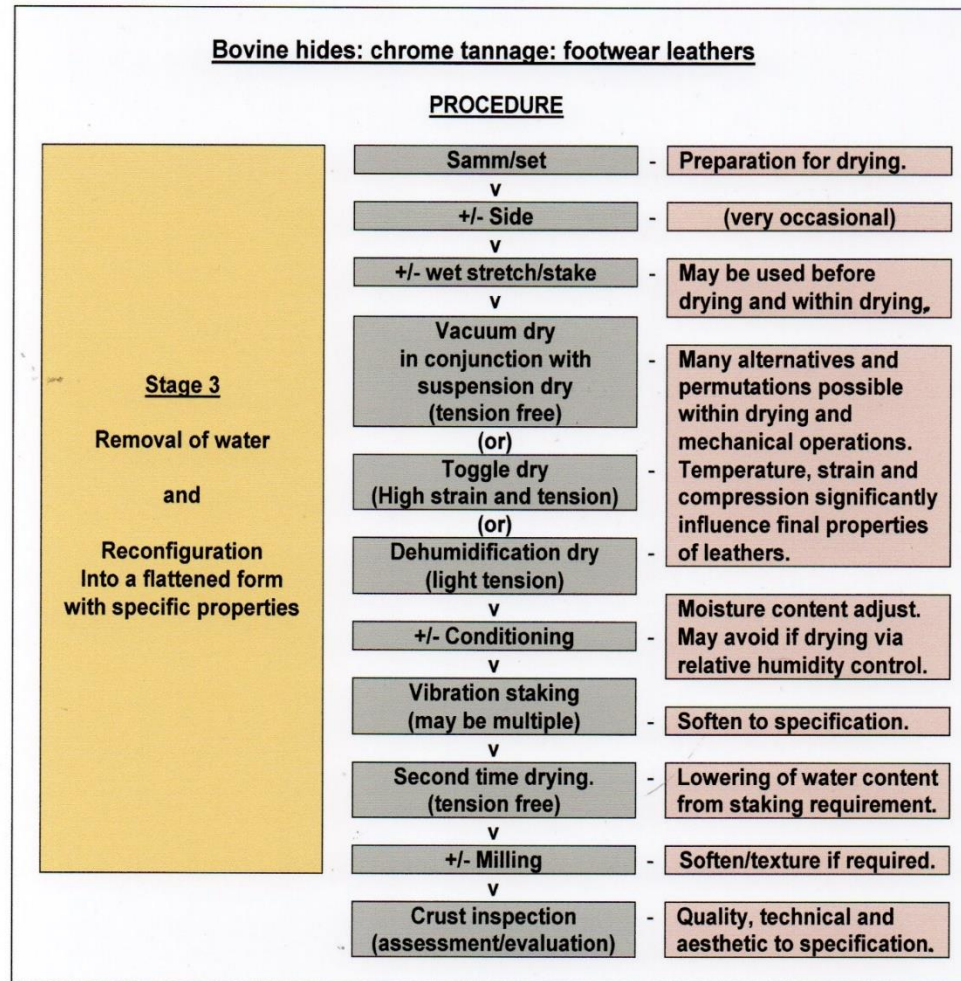

- Within Stage 3 procedures, water is removed from the structure.
- The mechanical operations used in preparation for this drying, followed by water removal by evaporation, produce a flat and useful substrate.
- The outcome from processes and operations used in Stages 1 and 2, are mainly completed within Stage 3 procedures.
- The extension of hides and skins from a natural rounded structure to a flattened form is finalised, providing very specific properties to the structure.

## PREPARATION FOR DRYING

**After retanning and fatliquoring processes, part of the water is removed mechanically from the structure in the samm/setting operation. This compresses and extends the structure, and flattens the grain surface for presentation to the main drying operations.**

**This compression and extension strongly affects the orientation of the fibre structure and, in turn, this influences the outcome from evaporation drying.**

**If pre-drying mechanical operations are not carefully managed, there can be significant variations in softness, the fineness of break, looseness and yield of the final leathers.**

## Pre-drying procedures

Sides discharge into steel containers.



Hand stacking leathers for draining.



- On completion of neutralisation, dyeing, retanning and fatliquoring processes, the leather is washed.
- This is to remove residual products and neutral salts from the structure.
- The drums are then unloaded, often into stainless steel containers.
- Leather can be stacked and drained before presentation to machine operations.
- Alternatively, the leather may be stacked flat in a container and covered in water to minimise pressure on pieces at the bottom of the pile.

## The samm/setting operation

The basic samm/set action.

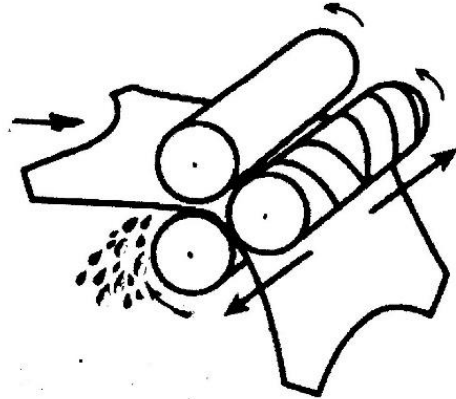

Presentation: the samm/setting operation.



- Leather is offered to the operation grain up.
- A strong setting action stretches out any creases before dewatering.
- The samming action gently squeezes water from the leather.
- It also compresses and consolidates the extended structure.
- There are many machine designs.
- Two diagrams are given for example.

## Samm/set machine (return action)

The cylinder/felt arrangement.

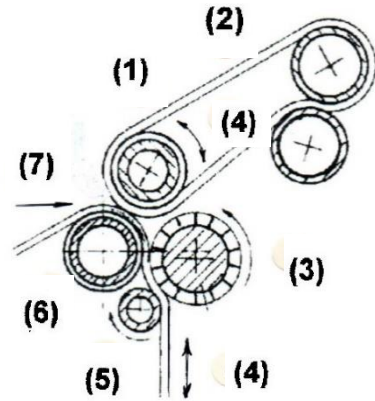

Turning leather after samm/set of butt area.



- 1) Upper pressure roller.
- 2) Felt dewatering belt (*may be felt roller only*).
- 3) Bladed setting cylinder.
- 4) Forward/reverse actions.
- 5) Anti-wrap rotor.
- 6) Support roller.
- 7) Leather grain up - samm/set action by forward/reverse movement.

Samm/set butt half, then turn by operatives and samm/set neck part.

Return action to operatives to complete cycle, with stacking for batch processing.

## The samm/setting machine (*through-feed action*)

Three roller through-feed arrangement.

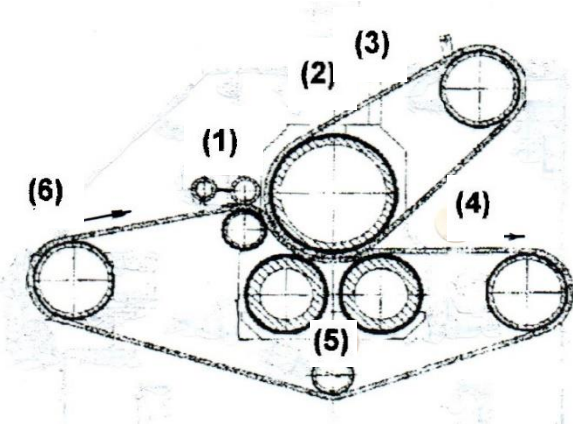

Presentation: samm/set operation.



- 1) Bladed spread roller assembly.
- 2) Upper pressure roller.
- 3) Upper felt dewatering belt.
- 4) Lower felt dewatering belt.
- 5) Support/pressure rollers.
- 6) Leather grain up - samm/set action by forward/reverse movement.

The leather is conveyed flat and extended from the operation.

When part of line production, out-feed may be directly to the next operation.



## The wet staking/stretching operation (*through-feed action*)

Basic wet staking/stretching action.

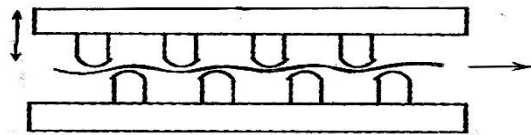

Samm/set - conveyor delivery to wet stretch/stake operation.



- **Leather is conveyed between twin belts and flexed/stretched using pins set on vibrating pressure plates.**  
*(This operation was introduced to leather manufacture in the 2000s. The machine design is essentially as the vibration staking machine (page 4/27) used since 1960s. Major actions within these variations are the same, but with refinement in pin size and movement.)*
- **These pins are larger in diameter than fitted to the conventional vibration staking machine, and provide an enhanced stretching action.**
- **Feed is often by conveyor after a through-feed samm/setting to this operation.**

**The wet stretch/wet staking machine.**

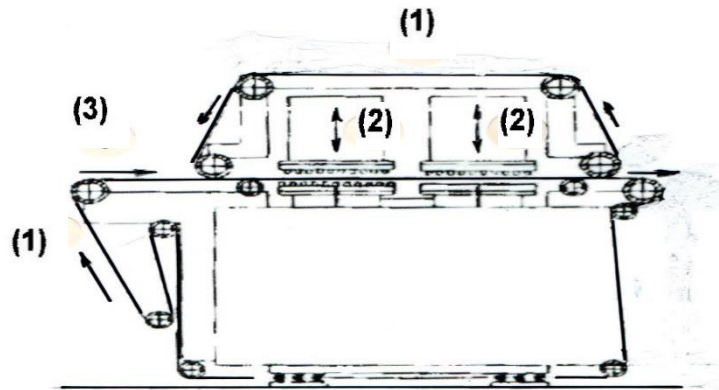

**Off-take with manual stacking.**



- 1) Flexible conveyor belts for transport of leather through machine.**
- 2) Oscillating rounded steel pins for fibre separation and stretching action.**
- 3) Leather offer grain up, movement as a through-feed operation.**

- The pin action both flexes and extends the damp compressed structure.**
- An overall loosening of the fibre matrix provides a softer leather.**
- This loosening assists the release of moisture on evaporation drying.**

## Review:

### ***Samm/setting operation:***

**After the retanning, dyeing and fatliquoring processes, the leathers are stacked in preparation for the mechanical removal of creases and excess water. This may enable some drainage of water from the leathers, but often leathers are stacked flat and immersed in water. This ensures a uniform saturation of leather throughout the batch, and minimises pressure on pieces at the bottom of the pile.**

**The most common pretreatment before drying is the samm/setting operation. This combines a light samming action with a strong setting or stretching action.**

### ***Wet stretching/staking operation:***

**This can follow the samm/setting operation. It reduces any over-compression from the samming action, and loosens the fibre structure. The stretching action extends the leather with area increase and reduction of grain indentations from samming felts for improved appearance. The fibre loosening appears to improve the release of water from the structure.**

**The wet staking/stretching machine was developed in the 2000s. The action is similar to the feed-through vibration staking machine used for mechanically softening dried leathers.**

## PREPARATION FOR DRYING.

**For bovine chrome tanned shoe upper leathers there are four major options for evaporation drying:**

- 1] Vacuum drying.**
- 2] Suspension drying.**
- 3] Toggle drying.**
- 4] Dehumidification drying.**

## 1] The vacuum drying operation:

The vacuum drying operation.

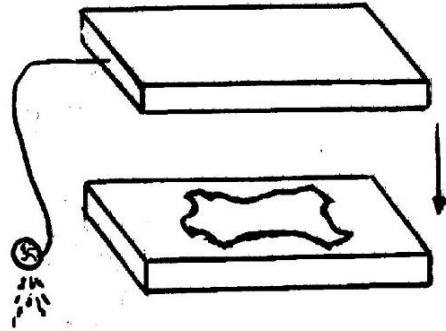

Multi-plate vacuum drying machine.



- Leather is placed grain down on a heated and polished stainless steel plate. *(sometimes sandblast plates are used to minimise minor grain defects).*
- A hood is lowered on a timed cycle to form a seal with the heated plate.
- Air pressure is reduced from the enclosed volume via the hood by vacuum pump.
- This lowers the boiling point of water causing fast evaporation.
- Vacuum driers were introduced to the sector in the 1960s and operate as multi-plate systems.

**Hand setting onto vacuum drying plates.**



**Leathers after mechanical loading.**

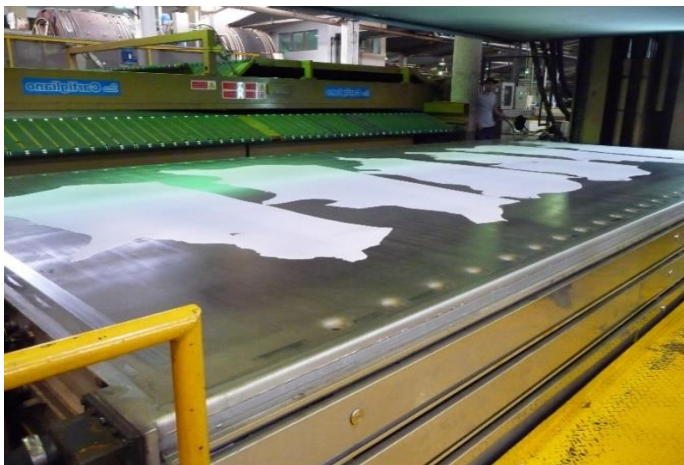

- **Leathers are extended by hand (*hand setting*) to avoid creasing.**
- **Mechanical loading systems are used, but operatives are needed to avoid pleating and for the removal of the dried leather.**
- **Temperatures of 45C and higher are common, but machines can operate at lower air pressures and temperatures.**
- **This method produces leather with a smooth grain, and sets the shape and area.**

**Pressure from the hood onto the leather increases as the air pressure is reduced. However, extended heat and pressure can cause over compression of the grain layer and corium. This can result in a firm leather and a deterioration of the break characteristics, especially if the plate temperatures are higher than 45C.**

**A balance is required. Normally the leathers are part vacuum dried only, completing the drying by tension-free drying (*suspension drying*) at a relatively low temperature.**

**The shape and area has been stabilised in the vacuum drying operation without developing excessive firming. The secondary slow evaporation under tension-free conditions to the required moisture content favours softness.**

## 2] Suspension drying:

**Tension-free: suspension/hang drying after part vacuum drying.**



**Leather suspended on horizontal poles fitted to a line conveyor.**



- **A tension-free slow drying used on its own will produce a very soft leather, with a tight break.**
- **It is a slow process and allows shrinkage. This results in area reductions, and a tendency to revert to a more rounded form.**
- **Horizontal pole conveyor systems are mainly used after vacuum drying.**
- **These systems mainly rely on warm air at a high level in the building.**
- **Temperatures can be raised within tunnels built around the conveyor if required.**



**Once used heavily within bovine manufacture, suspension drying was managed in sealed drying cabinets with air circulation and control of temperature and relative humidity.**

**It is normally used as a horizontal pole conveyor system as previously described, where drying of the part-vacuum dried leather is completed slowly and free of compression.**

### 3] Toggle drying:

Toggle drying under high tension.



Removal of leather from split frame.



- Leather is dried under tension by clipping (*toggling*) onto perforated frames.
- Frames are often made in two parts (*split frames*) to enable mechanical extension.
- This provides uniform strain and an increase in area.
- To ease loading/unloading, the frames can be pivoted to the horizontal.
- The drying takes place using forced air movement.
- The operation is managed by control of temperature and relative humidity.
- Makes a firmer and more extended leather than vacuum drying + suspension drying.

## ***Paste drying:***

***Vitreous plate awaiting paste spray.***

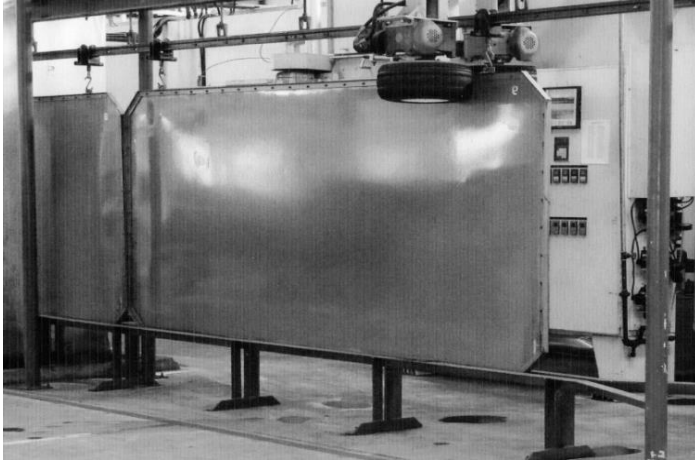

***Hand slicking - leather grain to plate.***



- ***This method is very effective, but now almost completely replaced by other methods.***
- ***It is, however, of technical interest.***
- ***Leather after samm/setting is stuck grain side to glass or vitreous enamelled plates using a starch based paste.***
- ***After controlled cabinet drying, the leather is peeled from the plates.***
- ***Paste is removed by either buffing or washing the grain layer.***
- ***Produces a highly extended, flat grained leather, with reduced stretch.***
- ***Evaporation from the flesh side only can result in surprisingly soft leather.***
- ***This technique is used very occasionally for speciality leathers, and is effective for drying splits.***

## 4] Dehumidification drying:

Manual presentation to dehumidification drying.



Off-set conveyor strings to maintain extension throughout drying operation.

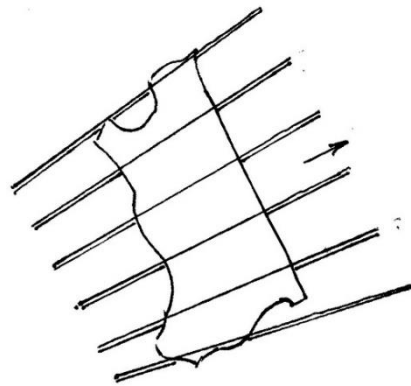

- Designed to follow wet stretching, leather is held horizontally and extended between pairs of feed-lines or strings.
- It is then dried using a series of air blades at moderate temperature as transported through the drying unit.
- The relative humidity (*RH*) is maintained by dehumidification.
- Moisture evaporates from the leather until there is an equilibrium between moisture retained in the leather and the designated *RH*.

**Out-feed from condition drying.**



**Auto-stacking under safe and secure conditions.**



- The carefully controlled RH allows drying to a specific moisture content throughout the whole structure.
- The leather is therefore in a suitable condition for mechanical flexing and softening.
- The horizontal out-feed lends itself to conveyor linkage directly into the vibration staking operation.
- The cycle can be completed by automatic stacking.
- This high level of machine linkages creates a very fast drying cycle to the pre-finished state.

## Review:

**Drying operations are not simply the removal of water. As water evaporates from the leather, the fibre structure is brought together at both macro and molecular levels.**

**Strong and permanent adhesions occur that reconfigure the structure into a specified shape. This shape is determined both by forces applied in preparation for drying operations and during evaporation. This results in a flattened form and a general hardening of the structure.**

**The final orientation of the fibre structure, and the adhesions that develop are very significant in the determination of the physical properties of the leathers produced.**

**Within leather drying, evaporation takes place in two phases:**

***1<sup>st</sup> Phase:***

**Removal of physically held water – taken as complete when signs of dampness disappear across the surface of the leather.**

***2<sup>nd</sup> Phase:***

**Removal of chemically bound water – from the end of Phase 1 to the final moisture content. Strong inter-fibre adhesions develop within this phase.**

**In general:**

**The greater the fibre compression, both before or during drying, the firmer and more compact the leather.**

**The greater the extension (*strain*) applied and maintained in drying, the firmer and thinner the leather, the coarser the grain, and the greater the area obtained.**

**The higher the temperature in Phase 2 drying the firmer the leather.**

**More moderate conditions provide improved grain break characteristics.**



## **POST DRYING OPERATIONS**

**The major physical properties and leather characteristics are determined by a combination of wet procedures and reconfigurations developed during water removal.**

**These properties can be amended to a degree in post drying mechanical operations.**

## The conditioning operation

**Leather conditioning by water spray.**



**Leather sealed to avoid moisture loss by evaporation.**



- Often, after vacuum/suspension or toggle drying the leather is too dry.
- A light water spray - usually on conveyor - is used to dampen the leather.
- This is followed by stacking to develop an even moisture content throughout the leather structure.
- The leather is tightly sealed during this time to avoid edge drying.
- The leather is then in a suitable condition for staking.
- The conditioning operation can be avoided if dehumidification drying is used.

## The vibration staking operation (*through-feed action*)

Combined vertical and horizontal action of staking/stretching pins.

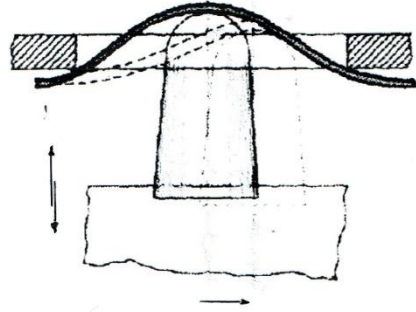

Feed to vibration staking operation.



- Leather is transported through the staking action sandwiched between flexible conveyor belts. (*Machine design: similar to arrangements pages 4/9 and 4/10.*)
- The frame mounted pins apply an articulated hammering action to the leather.
- Loosens weaker fibre adhesions.
- Softens and extends the structure.
- It is important to have the correct moisture content to avoid damage to the leather structure.
- This is followed by a short drying operation.

## Milling operation

The tumbling motion in milling.

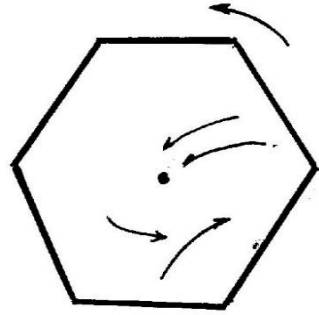

Hexagonal, octagonal and circular milling drum designs.



- To create very soft leather, further mechanical action can be applied after staking.
- Known as milling, the leathers are tumbled in dedicated drums for long periods to soften and loosen the structure.
- The leather contracts, forming very defined pebbled grain texturing.
- These effects are dependent upon previous processing, temperature, and the moisture content of the air circulating within the drum (*RH control*), and mechanical action.
- There are many different drum shapes and internal peg and shelf arrangements.

## Review:

### ***Conditioning:***

**The vacuum drying/suspension and toggle operations aim towards a uniform moisture content. However, due to cross-hide variations, drying is often irregular, and leather is often dried to a lower moisture content as this provides uniformity.**

**These leathers are usually too dry for staking and are slightly dampened or conditioned, usually by a water spray. They are then stacked in piles and left to achieve moisture equilibrium throughout the batch. This operation usually increases the moisture content from perhaps 12/18% moisture to 22/28% (*according to requirements*) in preparation for mechanical softening.**

**Drying by dehumidification enables uniform drying throughout the whole structure. This is determined by RH control, and the conditioning stage is avoided.**

### ***Vibration staking:***

**First-time drying operations are part of a significant structural change. At the time of drying, the shape and physical properties of the leather are determined by controlled adhesions throughout the fibre structure.**

**However, some of the weaker adhesions can be loosened at this stage and allow some softening and general relaxation.**

**This is normally carried out using a vibration staking machine, where a strong flexing/stretching action is applied to the leather. This causes a relaxation to provide the softness needed in the final material.**

**In the staking operation the moisture in the leather helps avoid overstressing the fibre structure and maintains break characteristics. If the leather is too dry at this stage, then softening can only be achieved by overstressing the structure. In this situation ruptures can occur within the fibre matrix, creating a coarse break and a deterioration of grain appearance.**

**A slow drying follows staking - usually tension-free (*second time drying*) - to reduce the moisture content to 12-16% dependent upon end requirements.**

***Milling operations:***

**Further softening can be developed by milling, where dry leathers are drum tumbled. The conditions of temperature, RH and time are closely controlled in this operation.**

**Together with carefully developed earlier processing, both softening and required surface effects can be developed.**

**Various additives may be sprayed into the drum to develop tactile and handle effects.**

### ***Rationalisation:***

**Highly rationalised conveyor systems suit large scale operations. Horizontal conveyors can link sabb/setting, wet staking/stretching and dehumidification drying to provide a leather with a moisture content suited for staking. Feed to a vibration staking machine (*multiple if needed*) can be added as well as automatic stacking.**

**Vacuum drying techniques with automatic loading can also be used instead of dehumidification drying, followed by drying free of tension.**

**There are many permutations within Stage 3 procedures, and processing times from the wet to pre-finished state can be reduced to one hour when operated as a production line system.**

**However, there are limitations dependent upon the range of leathers produced and scale of operation.**

**Small tanneries with a wide range of different leather types do not have the capacity for conveyor linkages and operate more effectively using batch operations.**



***Pre-finish assessment:***

**Leathers are normally inspected and graded after completion of the processes and operations described in Parts 1, 2 and 3 according to quality of grain, softness, colour, substance and suitability for customer specifications.**

**This is known as crust sorting, and ensures the leathers are in the optimum state before entering finishing operations.**



- **Free fibre movement is made possible in the first stage of leather making.**
- **In the second stage leather is made to suit customer needs.**
- **The final flat form is established in the third stage, with consolidation of the physical properties by managing the fibre adhesions.**
- **From a rounded and irregular waste from one industry, to a useful and valuable material to suit purpose.**

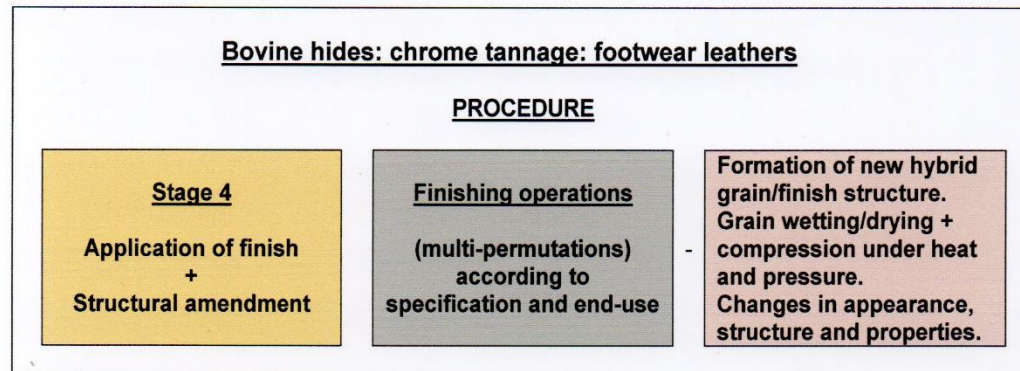

- Procedures set down in Stages 1, 2 and 3 provide leathers with properties to specification at the pre-finished state.
- Within finishing operations these leathers are tailored to suit both leather customer and end-user.
- The mix of physical and chemical properties developed within the leathers before finishing, and the finishes applied, need to work in synergy to achieve best results.